

**Requirements****Structural Measures on Seagoing Vessels  
for the Prevention of Marine Pollution  
by Oil, Sewage and Garbage**

(Protection of the Marine Environment)

The requirements listed below apply to new buildings that are subject to MARPOL 73/78 and the Helsinki Convention. Additional measures (see remarks in item 2) are applicable for the cargo tank area of ships carrying oil and oil products.

**1. Documents to be Submitted (including Certificates and Approvals)****We request in quadruplicate for each new building:**

- Details of structural measures in accordance with the accompanying form **MARP** “Structural Measures on Seagoing Vessels for the Prevention of Marine Pollution by Oil, Sewage and Garbage under MARPOL 73/78 and the Helsinki Convention (Protection of the Marine Environment)”,
- Submission of a schematic diagram showing the pipe work system of the oil-water separating equipment and the tanks according to **Appendix 2**, if there is any deviation from the standard pipe work system (in quadruplicate for each new building).

**2. Regulations**

A list of the regulations and recommendations on marine environment protection measures is given below. These include:

- International Convention for the Prevention of Pollution from Ships, 1973, as modified by the Protocol of 1978 relating thereto (cf. the German law arising from the International Convention for the Prevention of Pollution from Ships, 1973, and the Protocol of 1978 relating to the Convention, dated 23<sup>rd</sup> December 1981: BGBl. I 1982 p.2).
- First Ordinance for Implementing the Amendments to the International Convention for the Prevention of Pollution from Ships, 1973, as modified by the Protocol of 1978, dated 17<sup>th</sup> July 1985 (1. MARPOL-ÄndV) (BGBl. II p.868).
- Last amended by:  
Second Ordinance for Implementing the Amendments to the International Regulations of the environmental protection on sea traffic dated 9. April 2008 (Verordnung zur Änderung umweltrechtlicher Vorschriften in der Seeschifffahrt, BGBl. Teil I, Nr. 14, S. 698)

- Law of 30<sup>th</sup> November 1979 (BGBl. II, p.1229) relating to the Convention on the Protection of the Marine Environment of the **Baltic Sea Area** of 22<sup>nd</sup> March 1974 (Helsinki Convention 1974).
- - First Ordinance for Implementing the Amendments to the Annexes to the Convention on the Protection of the Marine Environment of the Baltic Sea Area (1<sup>st</sup> Amendment Ordinance on Baltic Sea Marine Environment Protection - 1. Ostsee-U-ÄndV -) dated 9<sup>th</sup> October 1980 (BGBl. II, p.1350) and the Second Amendment Ordinance on Baltic Sea Marine Environment Protection dated 21. December 2004 (2. Ostseeschutz-Änderungsverordnung, BGBl. II, S. 1667)
- Guidelines and Specifications for Pollution Prevention Equipment for Machinery Space Bilges of Ships, IMO Resolution MEPC.107(49).<sup>1)</sup>
- “Guidelines for the Development of Shipboard Oil Pollution Emergency Plans” published in Verkehrsblatt [Transport Gazette], Volume 24, 1994
- Recommendation on International Effluent Standards and Guidelines for Performance Tests for Sewage Treatment Plants, IMO Resolution MEPC.159(55) dated 13. October 2006.<sup>1)</sup>
- Recommendations on standards for the rate of discharge of untreated sewage from ships, IMO Resolution MEPC.157(55) dated 13. October 2006
- MARPOL 73/78 Annex I - VI
- Guidelines for systems for handling oily wastes in machinery spaces of ships incorporating guidance note for an integrated bilge water treatments system (IBTS)), MEPC.1/Circ.511
- COUNCIL DIRECTIVE 96/98/EC of 20<sup>th</sup> December 1996 on marine equipment supplemented by:
  - COUNCIL DIRECTIVE 98/85/EC of 11<sup>th</sup> November 1998
  - COUNCIL DIRECTIVE 2001/53/EC of 10<sup>th</sup> July 2001
  - COUNCIL DIRECTIVE 2002/75/EC of 02<sup>nd</sup> September 2002

The following requirements apply to all seagoing vessels, including oil tankers and product

---

<sup>1)</sup> Available from the International Maritime Organization (IMO),  
4 Albert Embankment, London SE 1 7 SR.

tankers. The additional measures for the cargo area of oil tankers and product tankers in accordance with MARPOL 73/78, Protocol, Annex I, are not taken into account in these requirements.

### **3. Dates when Provisions Come into Force and their Application**

MARPOL 73/78 with Annex I (Regulations for the Prevention of Pollution by Oil) came into force on 2.10.1983. Annex V (Regulations for the Prevention of Pollution by Ship's Garbage) came into force on 31.12.1988. The Annex IV entered into force is the 27.09.2003. The Helsinki Convention entered into force on 4<sup>th</sup> May 1980 and has been applied since 4<sup>th</sup> May 1981. The Ordinance on the Prevention of Pollution of the North Sea by Ship's Sewage entered into force on 15.06.1991. With the coming into force of the 3<sup>rd</sup> *Inkraftsetzungsverordnung Umweltschutz-See* the **North Sea** is according to MARPOL 73/78, Annex I, a special area. The Annex VI has entered into force on the 19.05.2005. Since the 19.05.2006 die Baltic Sea is a Sulphur Emission Control Area (SECA) and since 21.11.2007 also the North Sea is a SECA.

### **4. Structural Measures for the Prevention of Marine Pollution by Oil**

(MARPOL 73/78, Annex I; Helsinki Convention, Annex IV, Regulation 4)

Structural measures for the prevention of oil pollution shall be taken in accordance with **Appendix 1**.

The "Guidelines for Systems for Handling Oily Wastes in the Machinery Spaces of Ships incorporating guidance note for an integrated bilge water treatments system (IBTS)," were compiled by the Marine Environment Protection Committee (MEPC) of the International Maritime Organization (IMO), and adopted on 18<sup>th</sup> April 2006 as circular letter MEPC.1/Circ.511. The German version, entitled "*Richtlinien für Systeme zur Behandlung ölhaltiger Abfälle in Maschinenräumen von Schiffen einschließlich erläuternder Hinweise in Bezug auf ein integriertes System zur Behandlung von Bilgenwasser (IBTS)*", was published in the German Transport Gazette, Volume 2, 2007, page 15.

The tank sizes specified in **Appendix 1** take into account the tank calculations as per MEPC.1/Circ.511.

In compliance with IMO Resolution MEPC.107(49), oil filtration equipment for an oil content of 15 ppm (15 ppm equipment) and oil content meters with alarm devices shall be approved by type testing. Additionally an EC type approval certificate according to Council directive 2002/75/EC to amend the Council directive 96/98/EC on marine equipment is also required.

Oil filtration equipment normally comprises gravity oil/water separators and coalescer systems. Oil filtration equipment without gravity oil/water separators located upstream is not permitted. When necessary, a spare filter set is to be carried on board. 15 ppm bilge separator approved in accordance with MEPC.107(49) may be equipped in addition with membrane systems.

The standard pipe work system shall be designed in accordance with **Appendix 2**. Deviations from the standard pipe work system are permitted, but must be shown on the standard system diagram. Alterations are to be indicated in green colour and submitted separately.

The pump of the 15 ppm equipment may only discharge to sea via this equipment; bypassing is not permitted. The pipe work system of the 15 ppm equipment shall be separated from other drainage systems and the ballast systems, as well as from any oil

sludge systems, on both the suction and the discharge sides.

On ships of more than 4000 GT, the standard discharge connections for oil sludge according to MARPOL 73/78 Regulation 13 shall be provided on both the port and the starboard sides. In ships of up to 4000 GT, a single standard discharge connection is sufficient.

Sludge tanks shall be constructed in accordance with **Appendix 6** “Requirements for Sludge Tanks, including the Pipeline System, in Seagoing Ships Operating on Heavy Oil”.

Deep fuel tanks and double bottom tanks outside the machinery spaces and gravity fuel tanks shall be connected by overflow lines to a common overflow tank or an overflow system, e.g. overflow tanks integrated into the fuel tanks.

Oil sludge incinerators shall be constructed in accordance with **Appendix 3** “Oil Sludge Incinerators on Board Seagoing Ships”.

Provisions relating to permanently installed telephone links between the fuelling station on deck and the engine room are contained in the standard form “Mechanical and Electrical Equipment”.

According to regulation 37 of MARPOL 73/78, Annex I, every oil tanker of 150 gross tons and above and every ship other than an oil tanker of 400 gross tons and above which trades in national or international waters shall carry on board a “**Shipboard oil pollution emergency plan**”. In the case of ships to which regulation 37 of Annex I of the Convention applies, such a plan may be combined with the shipboard marine pollution emergency plan for noxious liquid substances as required under regulation 17 of Annex II of the Convention. In this case, the title of such a plan shall be “**Shipboard marine pollution emergency plan**”. After examination by the current classification society, Head Office, approval is granted by See-Berufsgenossenschaft.

For the compilation of emergency plans, the International Maritime Organization has compiled the “Guidelines for the Development of Shipboard Oil Pollution Emergency Plans” dated 6<sup>th</sup> March 1992 (MEPC.54/32). The German version was published as “*Richtlinien für die Erstellung bordeigener Notfallpläne für Ölverschmutzungen*” in the Verkehrsblatt [Transport Gazette], Volume 24, 1994.

**5. Structural Measures for the Prevention of Marine Pollution by Sewage**  
(MARPOL 73/78, Annex IV; Helsinki Convention, Annex IV, Regulation 5)

Structural measures for the prevention of marine pollution by sewage shall be designed in accordance with **Appendix 4**.

Sewage treatment plants require approval through type test certificates. Additionally an EC type approval certificate according to Council directive 2001/53/EC to amend the Council directive 96/98/EC on marine equipment is required.

For a definition of “sewage”, see MARPOL 73/78, Annex IV, Regulation 1, sect. 3 and the Helsinki Convention of 1974, Annex IV, Regulation 5, A, No. 1. In these documents “sewage” is referred to as **black water**. Effluent from kitchens, pantries, laundries, galleys, baths and showers is referred to as **grey water**, provided that it is not mixed with black water, and is not sewage as defined in the Conventions. **All drain water** from hospitals on board are sewage and therefore directly to connected to the black water system on board.

The sewage systems shall comply with the standards ISO 15749 Part 1 to 5 for drainage systems.

International **shore connections** for sewage shall be provided for collecting tanks as well as for sewage treatment plants (see MARPOL 73/78, Annex IV, Regulation 10 in conjunction with the appendix to Annex IV (blank certificate)).

Ships engaged only in national trade may be fitted with instantaneous connections instead of with the above-mentioned international shore connection.

Where a chlorine bleaching agent is used, the pipe work system including the valves shall be lined with plastic from the outlet of the sewage treatment plant to the hull skin, shall be made of corrosion-resistant material, or the internal surfaces shall be zinc-plated.

Direct sea discharge branches in the black water system shall be fitted with blind flanges. The sewage collection tank must be fitted with a level gauge or sounding device.

For ships of 400 GT or carrying more than 15 persons (crew plus passengers) an approved sewage treatment plant or a sewage holding tank with sufficient capacity shall be installed. Since the Annex IV entered into force the See-Berufsgenossenschaft will, after class inspection, issue an International Sewage Pollution Prevention (ISPP) Certificate for the above mentioned ships.

It is recommended to install in addition to the sewage treatment plant also an adequate holding tank for a temporary storage of sewage. Based on national laws some states may not allow the operation of sewage treatment plants in their ports or special sewage discharge areas.

If the discharge of untreated sewage from holdings tanks is carried out outside the coastal sea area the requirements of the resolution MEPC.157(55) shall be observed. In case that the discharge pumps on board are of a higher discharge capacity as recommended in MEPC.157(55) a special permission has to be given by the See-Berufsgenossenschaft.

**6. Structural Measures for the Prevention of Marine Pollution by Garbage**  
(MARPOL 73/78, Annex V; Helsinki Convention, Annex IV, Regulation 4)

Ships shall be equipped in accordance with **Appendix 5**.

It is recommended that to minimize the volume of garbage that ships shall be equipped with garbage compacting or shredding units in addition to the garbage collection containers.

Safe transportation of the garbage collection containers aboard ship and unloading off the ship shall be effected by mechanical equipment or other suitable measures.

Garbage collection containers shall have lids or suitable covers. (cf. SOLAS 74/88 Chp.II-2, Reg. 18(5))

Garbage shredders shall conform with the Safety Rules for Paper Shredders (ZH 1/493; obtainable from Carl Heymanns Verlag KG, 50939 Köln, Luxemburger Str. 449). This regulation is considered fulfilled if the plant has undergone a type test by Verwaltungs-Berufsgenossenschaft, Fachausschuss Verwaltung (Expert Committee for Administration), Hamburg.

A signboard in accordance with **Appendix 7** shall be displayed in the area in which the garbage collection containers are installed.

With Resolution MEPC 65(37), the Annex V to MARPOL 73/78 was amended and the new Regulation 9 appended. This concerns placards, garbage management plans, and the garbage record book. Resolution MEPC 65(37) was adopted on 14.9.1995 and came into force on 01<sup>st</sup> July 1997. A German copy of Regulation 9, "Placards, garbage management plans and the garbage record book" can be obtained from See-Berufsgenossenschaft.

**7. Structural Measures for the Prevention of Air Pollution by Ships**  
(MARPOL 73/78, Annex VI)

The Annex VI provides measures for the prevention of Air Pollution from ships. The Annex has entered into force on the 19.05.2005. New ships of 400 GT and above shall carry an “International Air Pollution Prevention Certificate” (IAPP Certificate) as the ship certificate and the “Engine International Air Pollution Prevention Certificate” (EIAPP Certificate) as engine certificates for diesel engines above 130 kW have to be issued to all ships where the keel was laid on or after the 1. January 2000 or which will undergo a major conversion from that date. Ships where the keel was laid before the 1. January 2000 shall have a valid IAPP Certificates not later than the 19.05.2008 and shall also have EIAPP Certificates in case of new installation or major conversions of their diesel engines after the 1. January 2000. Missing IAPP and/or EIAPP Certificates on board after the entry into force of Annex VI might be a reason for the detention of a ship.

**Structural Measures for the Prevention of Marine Pollution by Oil**

	Minimum throughput or minimum capacity	up to 400 GT	400 GT up to 1600 GT	1600 GT up to 4000 GT	4000 GT up to 15000 GT	15000 GT and over
15-ppm-equipment for special areas consisting of - 15-ppm-equipment <sup>2)</sup> - 15-ppm-alarm <sup>1)</sup> - shut-off device	m <sup>3</sup> /h	0,25	0,5	1,0	2,5	5
Sludge tanks <sup>3)</sup>	m <sup>3</sup>	2 % of the total capacity of all fuel tanks in m <sup>3</sup>				
Bilge water holding tanks <sup>4) 5)</sup>	m <sup>3</sup>	-	-	2	6	15
Leakage oil tanks <sup>5)</sup>	m <sup>3</sup>	1	1	1	1,5	2,5
Dirty- and waste-oil Tanks <sup>5) 6)</sup>	m <sup>3</sup>	1	2	3	8	10
Shore transfer pipeline	-	1 shore connection on the pt or stb side or amidships on the main deck, in accordance with MARPOL 73/78, Annex I, Regulation 13			2 shore connections on the pt or stb side of the main deck, in accordance with MARPOL 73/78, Annex I, Regulation 13	

**Legend to the “Structural Measures for the Prevention of Marine Pollution by Oil”**  
**(Appendix 1)**

- 1) 15 ppm alarm = oil content meter with 15-ppm alarm device; shut-off device = automatic stop of the discharge of oil-water mixture into the sea when the limiting value is exceeded.
- 2) The equipment table is laid out so that all ships with 15-ppm equipment shall be equipped for special areas. This meets the requirement according to MARPOL 73/78, Annex I, Regulation 10 (3) b vi.

On application by the shipping company, installation of the 15-ppm alarm and the shut-off device may be dispensed with on ships of up to 10,000 GT if the ship will categorically not be operating in special areas such as the Baltic or the North Sea.

Depending on the separation technology used (e.g. membrane filtration) a smaller 15 ppm bilge separator capacity can be permitted by the See-Berufsgenossenschaft.

- 3) Where equipment for burning oil sludge in accordance with **Appendix 3** is fitted, the total capacity of sludge tank and dirty-oil tank may be reduced by up to 30 % of the specified volumes. The minimum capacity for burning sludge shall be 1 % of the daily fuel oil consumption.
- 4) Bilge water holding tanks shall be provided where the SG (specific gravity) of the fuel exceeds 0,94, i.e. when operating with heavy fuel oil.
- 5) If the tanks are designed with capacities according to the above table, the requirements of the “Guidelines for Systems for handling Oily Wastes in Machinery Spaces of Ships” (MEPC.1/Circ. 511) are met.
- 6) If a complete lubricating oil change at sea is demanded for main and auxiliary diesel engines, the size of the tanks - in deviation from the values in the tables – shall be designed for at least 1,5 m<sup>3</sup> per 1000 kW engine output.

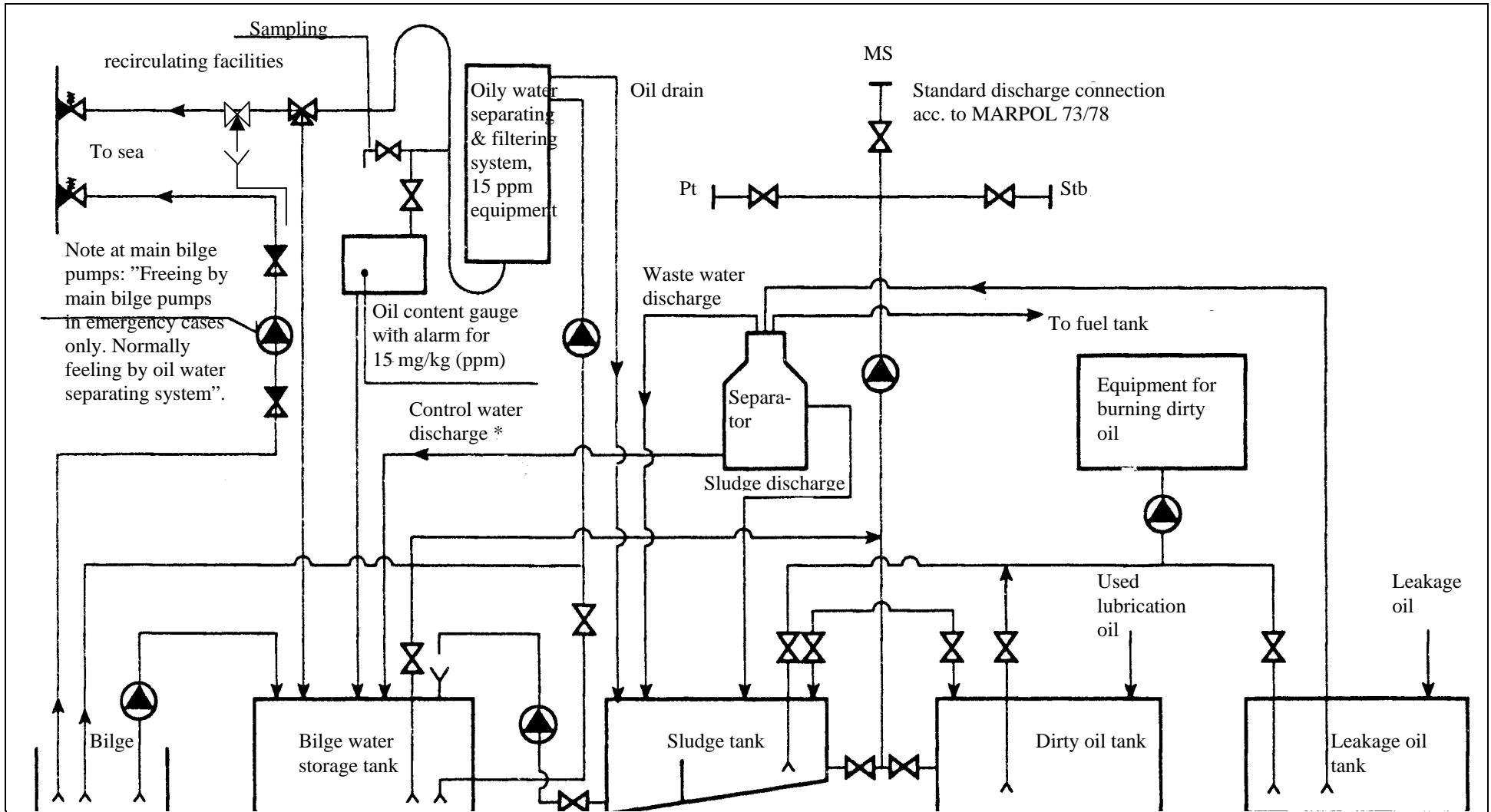

- Ship Safety Division

Appendix 2

Schematic diagram of the pipe work system for the oily water separating equipment and tanks

\*) not applicable for non-self-cleaning separators

**Oil Sludge Incinerators on Board Seagoing Ships \***

Garbage incinerators and sludge incinerators shall be in accordance with MEPC.76(40).

Forms A and B of the IOPP certificate under item 3.2.1 include questions about equipment for burning oil residues (oil sludge incinerators).

Oil sludge incinerators consist of an oil-firing plant and a combustion chamber, an oil sludge-conditioning tank (mixing tank), oil sludge preheater, double chamber filters and an homogenizer. Suitable oil firing plants and combustion chambers are those of auxiliary boilers, the heaters of heat transfer equipment or separate incinerators.

The oil burners must be suitable for burning oil sludge. For example, rotary cup burners are suitable.

The mixing tank shall be provided in addition to the sludge tank. It must be fitted with suitable oil/water separation equipment. A fuel connection shall be provided, for improving combustibility and raising the calorific value.

The homogenizer shall be so designed that the entire contents of the mixing tank can be conditioned to produce an homogeneous and combustible mixture. It may only be brought into operation after adequate de-watering of the tank. A device for continuous indication and monitoring of the water content of the oil sludge must be provided.

---

\*) See also "Guidelines for Systems for Handling Oily Wastes in Machinery Spaces of Ships incorporating guidance note for an integrated bilge water treatments system (IBTS)", MEPC.1/Circ.511.

**Structural Measures for the Prevention of Marine Pollution by Sewage**

		up to 400 GT	up to 400 GT and more than 15 Persons <sup>3)</sup>		Passenger ships from 400 GT up to 1000 GT <sup>3)</sup>		Passenger ships of 1000 GT and over	Seagoing ships except passenger ships of 400 GT and over <sup>3)</sup>	
			a	b	a	b		a	b
Approved sewage treatment plants in accordance with IMO Resolution MEPC.2 (VI) or MEPC.159(55) <sup>1)</sup>		-	-	x	x	-	x	x	-
Total capacity of sewage collection tanks <sup>2) 5)</sup>	Black water	-	70 l per person per day <sup>4)</sup>	-	-	70 l per person and day <sup>4)</sup>	-	-	70 l per person and day <sup>6)</sup>
	Grey- and Black water	-	180 l per person and day <sup>4)</sup>	-	-	230 l per person and day <sup>4)</sup>	-	-	180 l per person and day <sup>6)</sup>
International shore connection for sewage <sup>7)</sup>		-	x	x	x	x	x	x	x

x = available

**Design of Sewage Treatment Plants**

(Volume of sewage in litres per person per day)

	<b>Without vacuum plant</b>		<b>With vacuum plant</b>	
	Black water	Grey and black water	Black water	Grey and black water
Passenger ships	70	230	25	185
Seagoing vessels except passenger ships	70	180	25	135

Legend: s. page 14

**Legend to Table on page 12 and 13**

- 1) From the 01.01.2010 only sewage treatment plant approved in accordance with MEPC.159(55) shall be installed.
- 2) Discharge of untreated sewage at a distance of more than 12 nm from the nearest land with a ship speed of 4 kts.
- 3) The equipment shall conform either to column a or to column b.
- 4) If a vacuum plant is used for the sewage collection tank, the total tank capacity shall conform to ISO 15749.

- 5) Collection tank design  
For passenger ships navigating near the coast

Design shall be based on the following formula:

$$V_S = V_{PT} \cdot F_g \cdot x$$

where:

$V_S$	:	capacity of collection tank
$V_{PT}$	:	20 l per person per day grey and black water
$F_g$	:	number of passengers according to safety certificate
$x$	:	discharge after x days (x = 1, 2, 3 ...)

For excursion vessels and sportsmen's fishing boats

Excursion vessels and sportsmen's fishing boats should be equipped with a sewage collection tank of 1 m<sup>3</sup> capacity, unless there is insufficient space for a 1 m<sup>3</sup> tank or it can be proved that the sewage produced is less than this figure.

The sailing time for these vessels, as stated in the sailing permit, shall not be longer than 10 hours, and the owner of the vessel must confirm that the sewage is discharged regularly.

- 6) A 3-day holding period shall be assumed.
- 7) A quick action coupling may also be used for the vessels referred to in item 5 of the legend.

**Structural Measures for the Prevention of Marine Pollution by Garbage**

	up to 400 GT		400 GT up to 1600 GT	1600 GT up to 4000 GT	4000 GT up to 10000 GT	10000 GT and more	Passenger ships with over 50 persons
	up to 10 persons	up to 50 persons					
Minimum volume of garbage collection container (m <sup>3</sup> )	0,1	0,5	0,4	1,2	2,5	5,0	1,0 m <sup>3</sup> per 100 persons and day

According to the requirements over the development of Annex V of MARPOL 73/78 minimum three garbage containers for three different kinds of garbage shall be provided. It shall normally be assumed that the garbage is made up as follows: 50 % glass, cardboard etc., 25 % plastics and 25 % food waste. The capacity of garbage collecting containers can be reduced for ships in liner-service between two ports and for ships on short voyages.

If garbage incinerators, garbage compacting or shredding plants installed on board, the garbage container capacity can be reduced up to 50 %.

A separate steel container in accordance with § 181 of the Accident Prevention Regulations (UVV See) shall be provided for oily cleaning rags and cotton waste.

**Requirements for Sludge Tanks, including the Pipeline System,  
in Seagoing Ships Operating on Heavy Oil<sup>1)</sup>**

Sludge tanks plus the associated pipe work and pumps shall be designed as follows:

**1. Size of tanks and design of the pipeline system**

The size of sludge tanks and their connection to the pipeline system are laid down in the “Protection of the Marine Environment” requirements, **Appendix 1**, Status 01.01.2002.

**2. Location and design of the sludge tanks**

Sludge tanks shall be located above the double bottom, preferably above the floor, and – wherever possible – below the fuel separators. The sludge tank shall have a drain well or be so designed that the sludge runs down a slope to the suction aperture. Stiffening plates near the floor of the tank must leave openings large enough to allow an unimpeded flow of the sludge to the suction line.

The manholes shall be so located that accessibility to all regions of the tank is ensured for cleaning purposes. A manhole shall be provided near the opening of the suction line and another in the tank top, to permit the use of portable pumps. The separated waste water and the discharged control water from the fuel separator shall be taken to a special tank or into a sludge tank subdivided by a cascade (see schematic diagram in **Appendix 2**).

The sludge tanks, including the tank heating arrangements, shall be designed in accordance with the rules of the classification societies.

**3. Tank heating**

Sludge tanks for heavy oil separators shall be fitted with tank heating. The heating shall be so designed that the oil sludge can be heated to 60 °C. The heating pipes shall be so arranged that, when viewed from the entry point of the steam, they first run along the sidewalls and subsequently cover the entire area. The suction pipes from the sludge tank to the pump shall be provided with trace heating. The internal heating pipes shall be located high enough to prevent deposits in the tank from covering them.

---

<sup>1)</sup> See the “Guidelines for Systems for Handling Oily Wastes in Machinery Spaces of Ships incorporating guidance note for an integrated bilge water treatments system (IBTS)”, MEPC.1/Circ.511.

#### 4. Pump

The pump shall be of the self-priming displacement type suitable for pumping high-viscosity oil sludge. Furthermore, the pump installed shall be an oscillating displacement unit, e.g. a sliding-shoe pump, or a rotary displacement pump, e.g. an eccentric screw pump, with a minimum delivery head of 4 bar and dry-running capability.

The volume flow  $V'$  of the pump shall be determined from the following formula:

$V' = V/t$  ( $m^3/h$ ), where  $V$  is the volume of the sludge tank specified by See-Berufsgenossenschaft. The time  $t$  shall be assumed to be **four** hours as far as reasonable and practicable.

The volume flow of the pump shall be at least  $2 m^3/h$ .

The geodetic suction head of the pump may not exceed 2.0 m.

#### 5. Pipelines

Neither the pipelines to, nor those from, the oil sludge tanks may have any overboard connections.

The pressure side of the sludge pump may only be connected to the discharge line on deck and to an oil sludge incinerator. This pressure line shall be separate from the fuel intake line.

Where it is not possible to locate the sludge tank below the heavy oil separator, the discharge line must be run with the maximum possible slope down to the tank. The pipes should be laid as straight as possible, or with large-radii bends. Vent pipes from heated sludge tanks must terminate on the open deck. Steaming-out pipes should be fitted in the upper part of the sludge tank.

**Treatment of garbage from ships**

Garbage from ships has to be separated according to the table below and collected in containers or garbage rooms.

The discharge of ship generated garbage to port reception facilities shall be given first priority.

The disposal of ship generated garbage into the sea is only possible following the order of the Master or Officers observing the table listed hereafter.

Garbage	Disposal of garbage into the sea	
	Outside special Areas	Special Areas <sup>*)</sup>
All plastics, including synthetic ropes, synthetic fishing nets and plastic garbage bags	prohibited	prohibited
Dunnage, lining and packing materials which will float	25 nautical miles from the nearest land	prohibited
Paper products, rags, glass, metal, bottles, crockery and similar refuse	12 nautical miles from the nearest land	prohibited
Food waste	12 nautical miles from the nearest land	12 nautical miles from the nearest land

<sup>\*)</sup> Baltic Sea, North Sea including English Channel, Wider Caribbean Region including Gulf of Mexico, Caribbean Sea, Bahamas, Greater and Lesser Antilles (Wider Caribbean from April 1993 on), Antarctic, Mediterranean Sea, Black Sea, Persian Gulf area, Red Sea (see MARPOL 73/78 Consolidated Edition 2006 Annex V Reg. 5 (1) Pages 363/364)

**Note:** For ships in Great Coastal Service and Restricted International Service the signboard should only show Baltic Sea, North Sea and Mediterranean Sea.